

PRODUCT CONSTRUCTION EXAMPLE

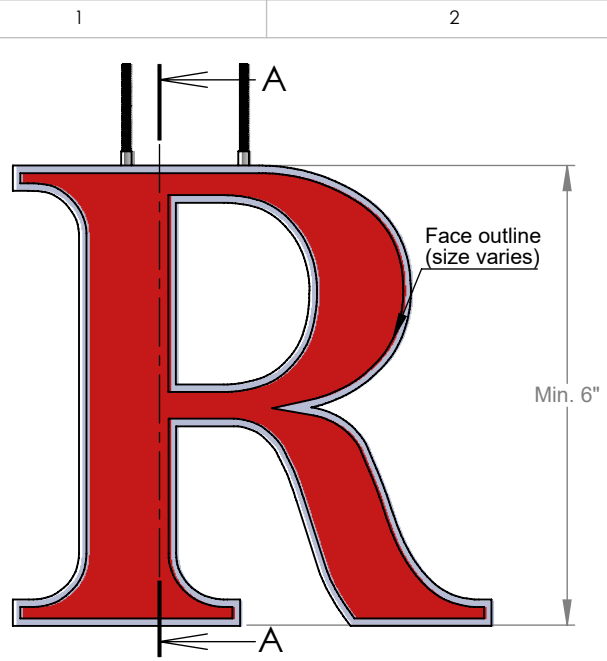

FRONT VIEW II SCALE 1:5

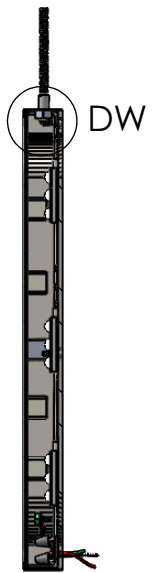

SECTION A-A II SCALE 1:5

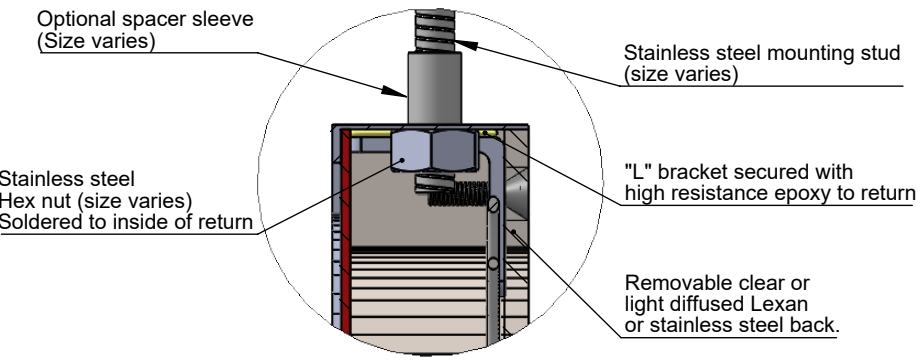

DETAIL DW II SCALE 1:1.5

- NOTES:**
- Minimum 1" stroke, min. 2" deep
 - This mounting option is recommended for interiors only
 - Tie backs required (not supplied) on letters > 8" high

BACK OPTIONS

- Clear Lexan: 6-12" high - 0.118 thick
- Light diffused Lexan: 0.177" thick
- Stainless steel - same gauge as face

MATERIAL OPTIONS

- Standard - 304 prefinished stainless steel
- Optional - 316 prefinished stainless steel (more corrosion resistant)
- 304 prefinished stainless with titanium coating

| INSERT OPTIONS | |
|-----------------|------------------------------|
| Stainless steel | 18-20 gauge up to 24" high |
| Acrylic | 3/16" thick - up to 36" high |

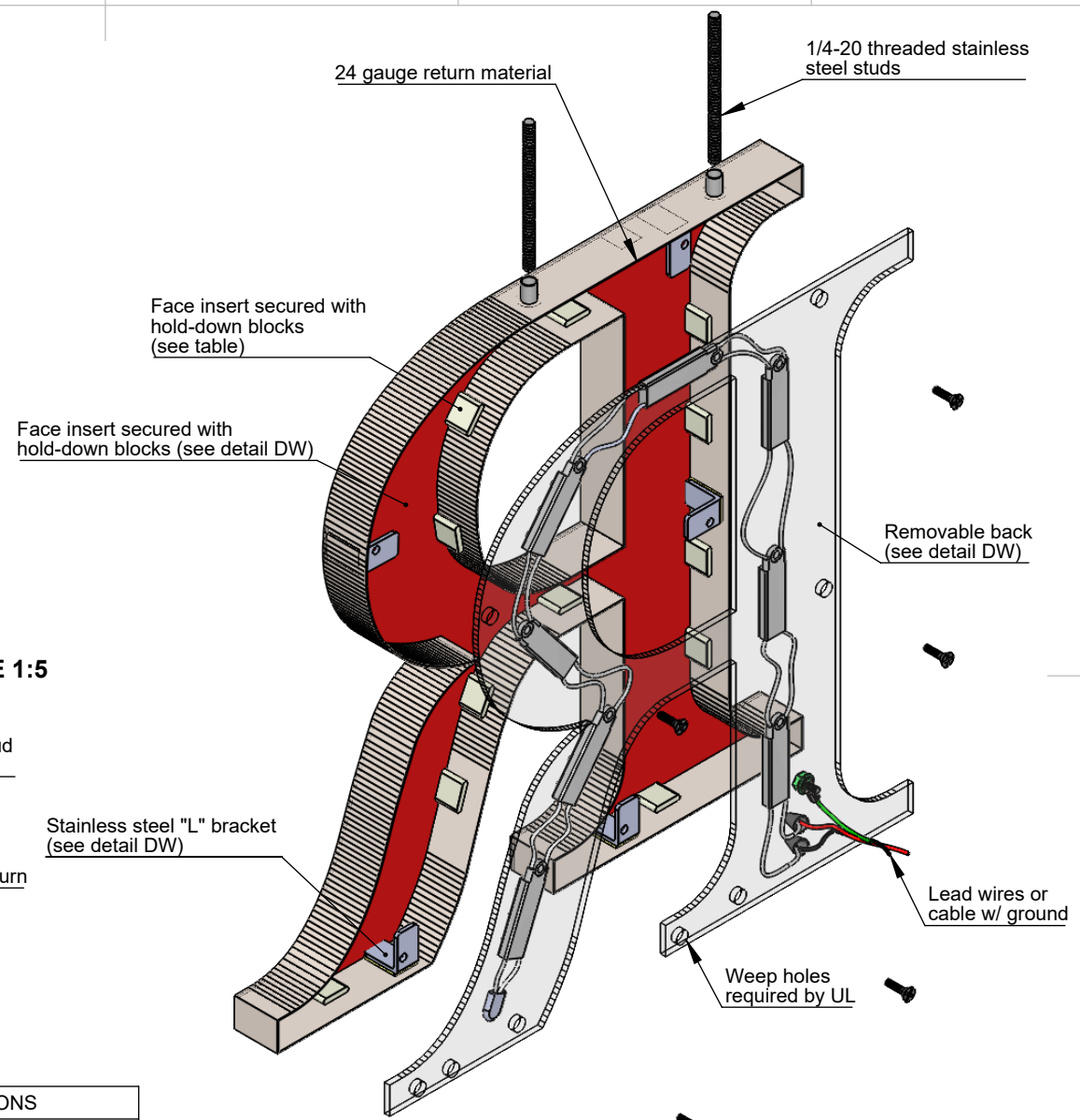

ISOMETRIC BACK VIEW II SCALE 1:3

| | |
|--|--|
| TITLE: FACE LIT - WITH LEDS - TOP STUD | |
| MATERIAL: STAINLESS STEEL | PRODUCT TYPE: FABRICATED METAL |
| DWG NO. FABL220L | REV 12/3/16 |
| SCALE: AS INDICATED | SHEET 1 OF 1 |