

FRONT VIEW II SCALE 1:5

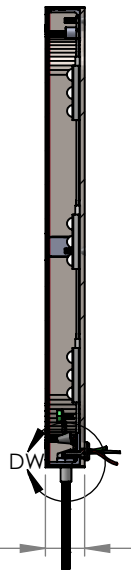

SECTION A-A II SCALE 1:5

24 gauge return material - up to 24" high
22 gauge return material - over 24" high

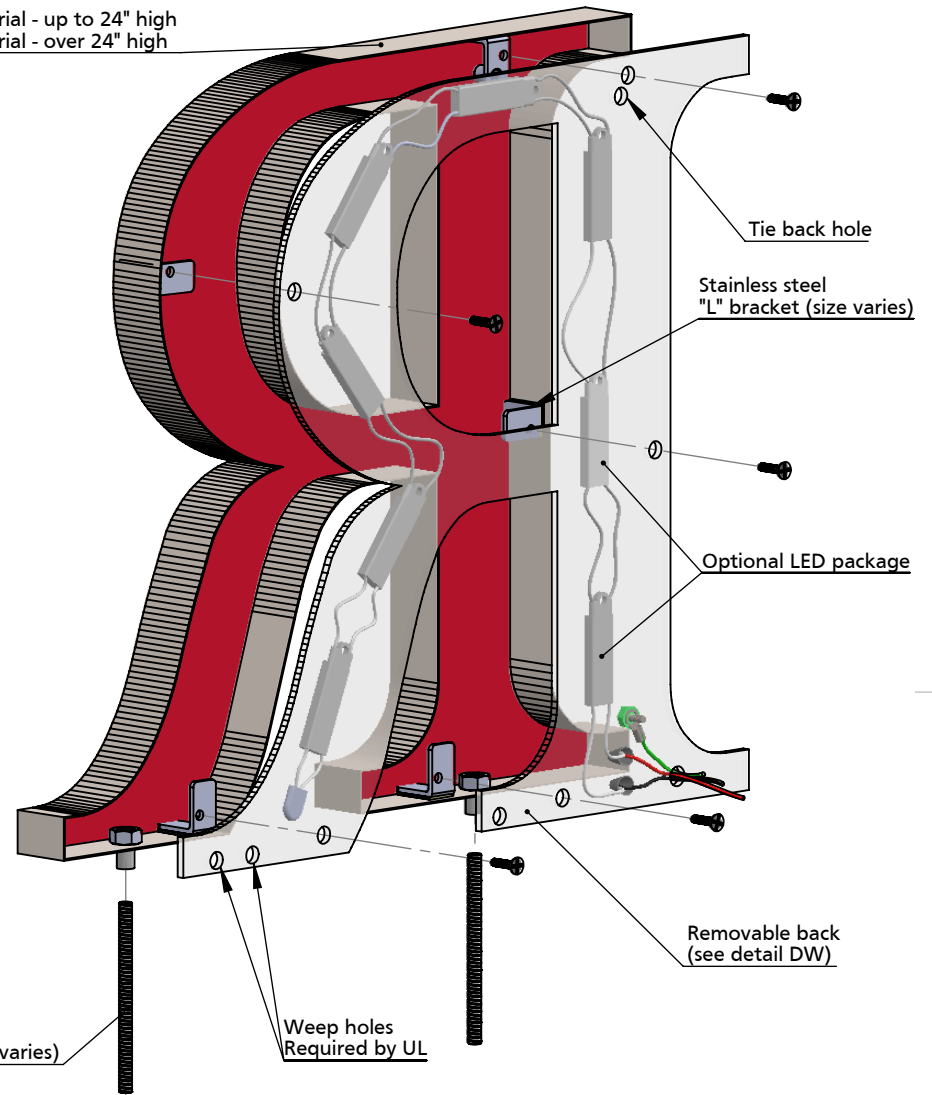

ISOMETRIC BACK VIEW II SCALE 1:3

Face insert secured with hold-down blocks (see table)

Removable clear or light diffused Lexan or stainless steel back. Requires tie back with letters over 8" (not included)

Flush back secured with stainless steel screw

"L" bracket secured with high resistance epoxy to return

1/4-20 stud (size varies)

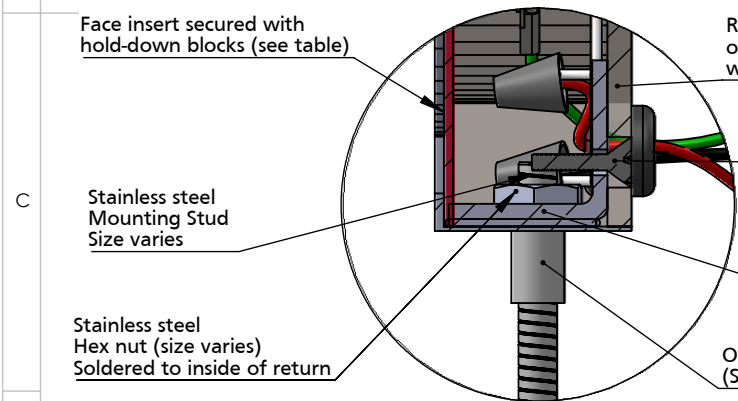

DETAIL DW II SCALE 1:1

BACK OPTIONS

- Clear Lexan: 6-12" high - 0.118 thick.
- Light diffused Lexan: 0.177" thick
- Stainless steel - same gauge as face (optional: 1/8" thick metal back)

INSERT OPTIONS	
Stainless steel	18-20 gauge up to 24" high
Stainless steel	16-18 gauge over 24" to 36" high
Acrylic	3/16" thick - up to 36" high

MATERIAL OPTIONS

- Standard - 304 prefinished stainless steel
- Optional - 316 prefinished stainless steel (more corrosion resistant)
- 304 prefinished stainless with titanium coating



TITLE:

**CUT OUT FACE WITH INSERT - BACK FOR LED'S
BOTTOM STUD**

MATERIAL:

STAINLESS STEEL

PRODUCT TYPE:

FABRICATED METAL